

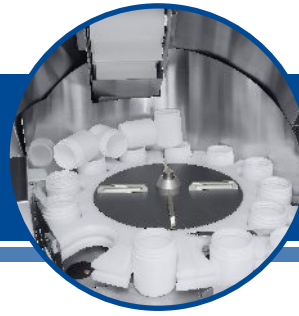

BOTTLE UNSCRAMBLER CVC 1263E



✓ Specially designed to meet the packaging line requirements in pharmaceutical and nutraceutical industries.

✓ Compact design with enclosed built-in hopper and starwheel disc sorter for noise elimination and space saving.

✓ Control panel features simple operation.

STANDARD FEATURES

- Type 304 stainless steel bin, frame, enclosure panels.
- Maximum speed is 80 bottles per minute. (based on 100 cc round bottle size)
- Stainless steel frame and transparent shield for operator safety and isolation from dust.
- Bottle orientating assembly is accurate, adjustable and user friendly.
- Adapting Mitsubishi PLC.
- Bottles are discharged upright and properly arranged onto existing conveyor.
- PLC Controlled.
- Variable speed motors.
- Locking casters as standard feature.
- Full cGMP compliance.



CVC 1263E Technical Specifications

Type	E
Speed	Up to 80 Bottles per Minute (BPM)
Hopper Capacity	14 cu. ft.
Bottle Height	2" to 5 7/8" (50mm - 150mm)
Bottle Diameter	1 1/8" to 3 1/8" (30mm - 80mm)
Power Source	220V, 50 Hz, 1 Phase
Power Consumption	450 W
Air Pressure	Minimum 87 psi (ISO 8573-1)
Air Consumption	2.1 cfm (60 L/sq. cm)
Machine Dimensions	L. 3'-2" x W. 5'-6" x H. 6'-5" (L. 953 mm x W. 1680 mm x H. 1967 mm)
Machine Weight	661 3/8 lbs. (300 kg)
Packing Weight	771 5/8 lbs. (350 kg)
Noise Level	78 dB

TECHNICAL SPECIFICATIONS

AVAILABLE OPTIONS

- Bottles are discharged upright and properly arranged onto existing conveyor.
- PLC Controlled.
- Variable speed motors.
- Locking casters as standard feature.
- Full cGMP compliance.



Bottle Sorter:

The starwheel type bottle orientating and sorting assembly works precisely and is easy to be adjusted.

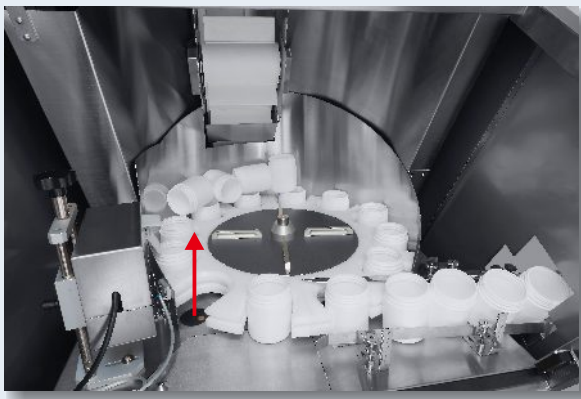

Bottle Orientation:

Use a air blowing device to eject the upside down bottle back to the starwheel sorter for further sorting.

MACHINE LAYOUTS

Top View

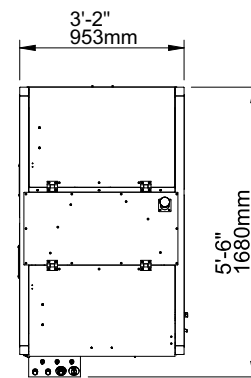

Front View

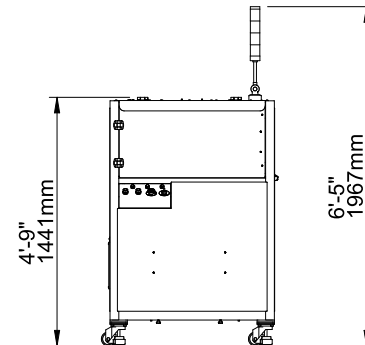

The dimensions shown are for standard machine. The conveyor can be extended: the length may vary based on selected options. This machine can run independently or be integrated into an automated packaging line. All CVC equipment is covered by a one-year parts warranty. Full Warranty details are included in our equipment proposals or can be found on our website.



Contact Us

USA
10861 Business Drive, Fontana, CA 92337
Phone: +1 (909) 355-0311
www.cvctechnologies.com
sales@cvcusa.com

USA East Coast Office
1855 New Highway, Suite C, Farmingdale NY 11735
sales@cvcusa.com

Taiwan-Asia Pacific Headquarters
Phone: +886 (4) 2496-3666
sales@cvctechnologies.com

China/India/Indonesia
sales@cvctechnologies.com